



CONTROL CONCEPTS

1029C

Single Phase Phase-Angle SCR Power Controller

Features

- Phase-Angle Control
- Linear control of RMS Voltage, RMS Current or Load power with respect to a command signal independent of line voltage variations
- Adjustable Current Limit
- Adjustable Over Current Trip
- Shorted SCR Detection
- Soft Start with Missing Cycle Detection
- Run & Idle Command Inputs
- Operates at 50 or 60 Hz
- Output signals representing load current and voltage
- Plug-In & Interchangeable Circuit Card
- Diagnostic/Status LEDs
- Optical Coupled Gatedrives
- Over Temp Protection (T-Stat on Heat Sink)



Description

The model 1029C is a single phase, phase-angle SCR power controller. The controller linearly controls, with respect to a command signal, either the RMS value of the load voltage, the average value of the load voltage, the RMS load current or load power. The controller can be configured to accept all standard industrial command signals as well as many non-standard commands.

The model 1029C is available with current ratings from 50 to 750 amperes, and nominal voltage ratings from 120 to 575 Vac. The controller will operate without adjustment or modification on 50 or 60 Hertz.

1000 and 2000 amp units, although not UL listed, are available, consult factory.

The model 1029C is intended for controlling transformer coupled loads, fast responding loads, and non-linear loads such as tungsten, silicon carbide, and molybdenum disilicide.

(Continued on page 2)

Applications

- Variable Resistance Loads
 - Silicon Carbide
 - Molybdenum Disilicide
 - Graphite
- T-3 Lamps
- Transformer Coupled Loads
- Fast Responding Loads



Description (cont'd)

Current Limiting.

Current limiting prevents the load current from exceeding a preset, user adjustable, value. This feature can prevent loads with low cold resistance from drawing excessive startup current. Current limiting can also be used to limit the maximum power applied to a load.

Over Current Trip.

The over current trip provides an adjustable means to remove power when a load fault occurs. The over current trip feature, in the event of excessive current, prevents the SCRs from being turned ON and energizes a relay with form "C" contacts. The relay contacts can be used to activate an alarm or remove system power. The over current trip is preset at 150% of the current rating of the controller. The relay and operation of the controller is reset by momentary closure of a remote contact or by removing power from the controller.

Shorted SCR Detection.

A relay with form "C" contacts is energized in the event an SCR fails in the ON state allowing full power to be continuously applied to the load. The relay contacts can be used to activate an alarm or to cause system power to be removed.

Soft Start.

Soft Start sets the output to zero on startup or after a momentary power interruption and then ramps the output to the desired level at a predetermined rate.

Run & Idle Input Command Signal Selection.

Closure of a remote contact changes control from the IDLE command input to the RUN command input. This provides a convenient method of switching from auto to manual or from a RUN condition to an IDLE condition.

Reset.

Momentary closure of a remote contact resets the controller and Over Current Trip relay. Soft Start is initiated. The Reset input may also be used as a Run/ Stop control input.

Optically Coupled SCR Gate Drives.

Optically coupled SCR gate drives provide superior transient immunity and electrical isolation rather than conventional techniques using pulse transformers. This technique virtually eliminates false operation and prevents SCR failure that can result when SCRs are not properly gated into the on state.

Metering Outputs for Load Voltage, Load Current or Power.

A 0 to 5 Vdc signal proportional to the RMS value of the load voltage and a 0 to 5 Vdc signal proportional to the RMS value of the load current are provided for monitoring the controller output.

A 4 to 20mA metering output proportional to RMS load power is a factory option.

Diagnostic LEDs.

The diagnostic/status indicating LEDs provide a convenient and safe method of analyzing the operation of the controller.

- Command LED.

Varies intensity with the level of the applied command signal.

- Load Current LED.

Varies intensity with the level of current in the load.

- Over Current Trip LED.

Indicates that over current trip has been activated.

- Shorted SCR LED.

Indicates that an SCR has failed in the ON state.

Wiring

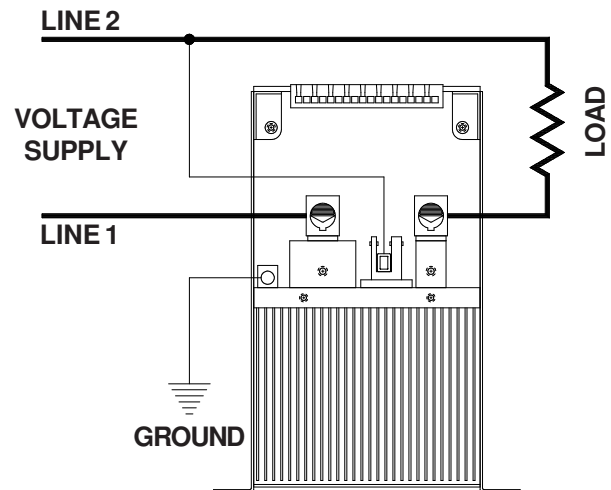

Power connections

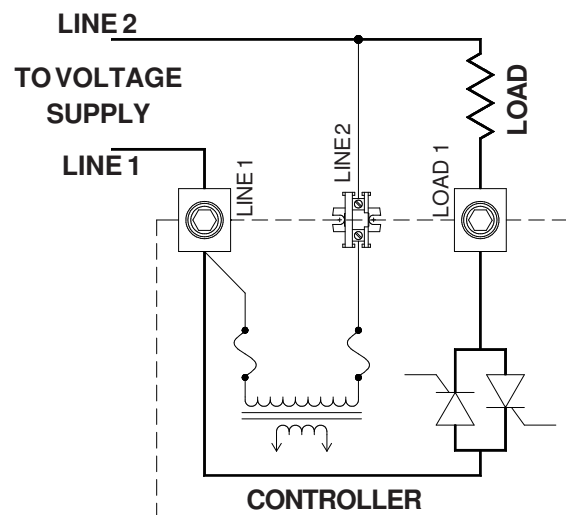

Power path

Note: Fuses and a disconnect are recommended in the voltage supply lines.

Dimensions

(inches)

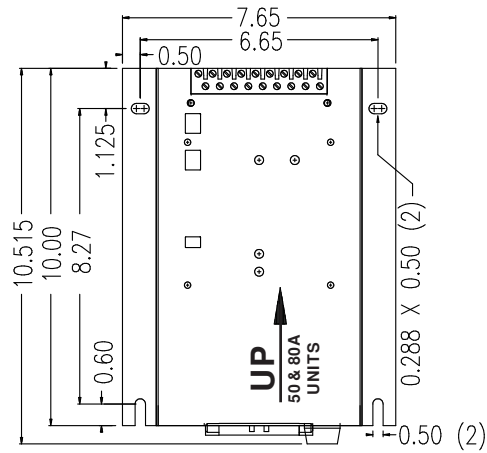
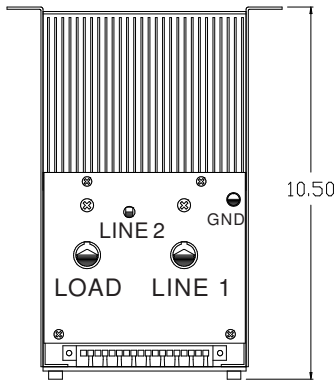

50, 80, 120 & 160 Amps

50 & 80 Amp units are convection cooled and must be mounted so that the heatsink fins are vertical.

The 120 & 160 Amp units are fan cooled and may be mounted in any direction.

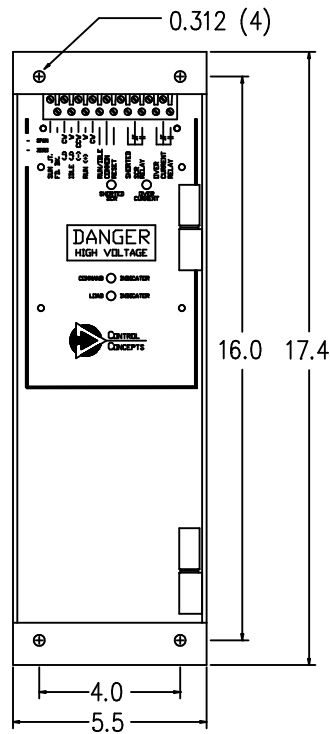
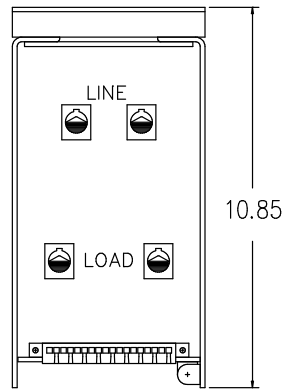

The 200, 250, 300, 380 & 425 Amp units are fan cooled and may be mounted in any direction.

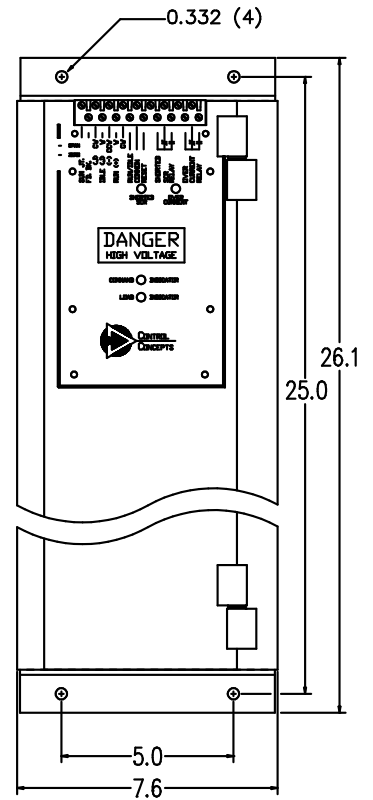
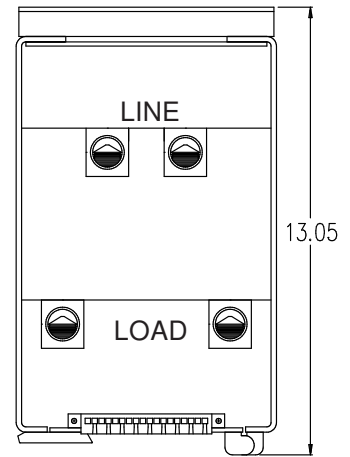

The 500, 600 & 750 Amp units are fan cooled and may be mounted in any direction.

LUG / WIRE SIZE

Frame Size Amps	Number of Lugs	Recommended Wire Size
50-160	2	6ga-250MCM
200-425	4	6ga-250MCM
500 - 750	4	1/0ga-500MCM

FIELD WIRING OF CARD CONNECTOR

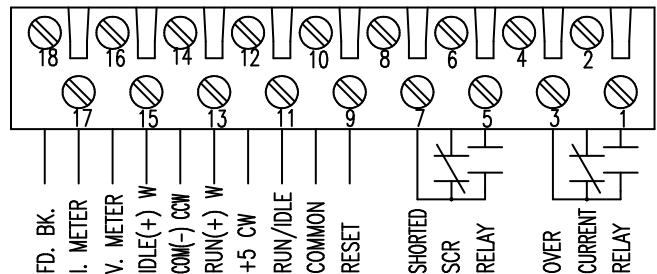

Specifications

Control Mode(s)	Single-phase, phase angle control of RMS voltage, RMS current, average voltage or power applied to the load. External feedback control is also available.	Line Voltage	120, 240, 480, and 575 Vac, +10%, -15%, 50/60 Hz. Other voltages available.								
Command Signal	<table border="0"> <tr> <td>Signal</td> <td>Impedance</td> </tr> <tr> <td>0-5Vdc</td> <td>200K Ohms</td> </tr> <tr> <td>1-20K Pot.</td> <td>200K Ohms</td> </tr> <tr> <td>4/20mA</td> <td>300 Ohms</td> </tr> </table>	Signal	Impedance	0-5Vdc	200K Ohms	1-20K Pot.	200K Ohms	4/20mA	300 Ohms	Line/Load Connections	Compression lugs provided for copper wire connections. 50 to 425 Amps 6 ga to 250MCM 500 to 750 Amps 1/0 to 500MCM
Signal	Impedance										
0-5Vdc	200K Ohms										
1-20K Pot.	200K Ohms										
4/20mA	300 Ohms										
Control Range	0 to 98% of line voltage.	Load Current	Models available with current ratings of 50, 80, 120, 160, 200, 250, 300, 380, 425, 500, 600 & 750 (1000 & 2000A, consult factory).								
Linearity	Output is linear within 2% of span over entire range of control.	dv/dt and Transient Voltage Suppression	200 Volts/microsecond minimum. Uses a dv/dt snubber and a metal oxide varistor (MOV).								
Zero and Span	Factory preset.	Cooling	Convection cooling on 50A & 80A units. Forced air fan cooling on all others.								
Current Limit	User adjustable over a range from 20% to 105% of rated current.	Weight	50A and 80A, 16 pounds; 120 and 160A, 17 pounds; 200A thru 425A, 21 pounds; 500A thru 750A, 40 pounds.								
Over Current Trip	Adjustable. LED indication and Form "C" relay contacts for output. Preset at 150% of rated frame current.	Temperature	Operating: 0 to +55 C (+32 to +131 F) Storage: -40 to +80 C (-40 to +176 F)								
Isolation	Dielectric strength, input/output and load voltage/heatsink: 2500V(RMS)	Heat Dissipation	1.5 Watts per amp of controlled current.								
Mounting	Convection cooled: Heatsink fins vertical. Forced air cooled: any orientation.	Fusing	Special semiconductor fuses are not required. Class T fuses are recommended to protect controller and load.								

Ordering Information

1029C - (X) - (XXX)V - (XXX)A - IL(XXX) - R(XXX) - I(XXX)

Model Number _____

Feedback Type _____

V = RMS Voltage, A = Average Voltage
I = RMS Current, E = External (0/5 Vdc)
P = Power

Operating Voltage _____
120, 208, 240, 277, 380, 415, 480, or 575 Vac.

Operating Current _____
50, 80, 120, 160, 200, 250, 300, 380, 425, 500, 600 & 750
(Consult factory for 1000 & 2000 Amps)

Current Limiting _____
Up to 105% of controller rating.

Run Command Signal _____
0/5Vdc, 4/20mA or Potentiometer

Idle Command Signal _____
0/5Vdc, 4/20mA or Potentiometer

Complementary Products

Control Concepts, Inc., with a full range of standard and custom SCR power controllers and signal conditioners, has the expertise to meet your specific industrial power control needs. All of Control Concepts products are covered by a limited two year warranty. Call us for answers, and delivery schedules that work.

Manufactured by



800.765.2799 | www.ccipower.com
Phone: 952.474.6200 Fax: 952.474.6070
7870 Park Drive, Chanhassen, MN 55317, U.S.A.