

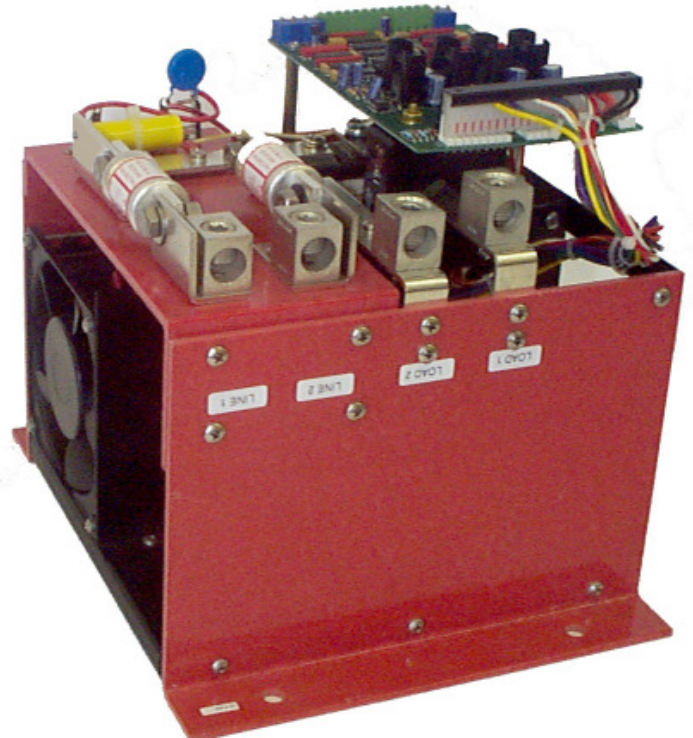

Single-Phase Phase-Angle SCR Power Controller

Features

- Linear control of RMS Voltage, RMS Current or Average Voltage with respect to a command signal independent of line voltage variations
- Diagnostic/Status LEDs
- Voltage and current metering Outputs
- Soft start and missing cycle detection
- Optical Coupled Gatedrives
- Built-in Line Fuses
- Optional Plug-in board adds:
 - √ Current Limiting
 - √ Shorted SCR Detection
 - √ Over Current Trip
 - √ Idle Command



Description

The model 1039 is a phase-angle SCR power controller for use in a single phase application. The power applied to the load is linear with respect to the command signal.

Available command signals include 0 to 5Vdc, 0 to 10Vdc, 4 to 20mA or potentiometer.

The model 1039 is available with current ratings from 10 to 180 amps and voltage ratings from 120 to 575Vac. The controller will operate without adjustment or modification on 50 or 60 hertz.

The model 1039 circuit uses a digital phase locked timing technique to accurately determine the turn on time of the SCRs.

Applications

- Inductive Loads
- Tungsten Lamps
- Capacitive Loads
- Resistance Heating
- Transformer Coupled Loads

Wiring

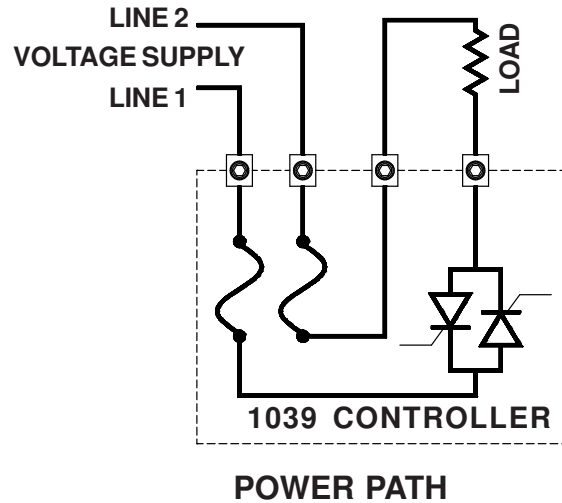
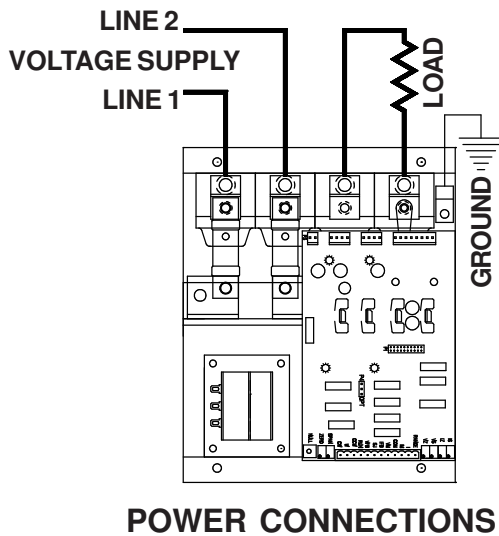

Specifications

Control Mode(s)	Single-phase, Phase-angle control of the RMS voltage or the Average voltage or the RMS load current, depending on the model.
Command Signal	Standard control signals such as 0 to 5Vdc, 4 to 20mA or potentiometer.
Control range	0 to 98% of the line voltage
Linearity	Output will be linear within 0.5% of span over entire range of control.
Zero & Span	Factory preset

Line Voltage	120, 208, 240, 277, 380, 415, 480 & 575Vac.
Cooling	Convection 50 & 75 Amp frames. Forced air on 180 Amp frames.
Dissipation	Approximately 1.5 Watts per Amp of load current
Isolation	Heat sink to supply and load Voltage 2500 Volts peak. Control signal to supply and load 1500 Volts peak.
LED Indicators	Led's show the status of the Load Current, Line OK and Gate Drives.

Ordering Information

1039 - FB - (vvv)V - (aa)A - F(ff) - (CS)

1039 Basic model number.

FB Indicates the type of control

V = RMS voltage control

I = RMS current control

A = Average voltage control

(vvv)V = Frame Voltage; 120 to 575Vac

(aa)A = Current at which meter output equals 5Vdc.

Also maximum output current when load current is controlled.

F(ff) = Fuse Rating.

(CS) = Type of command signal: 0 to 5Vdc, 4/20mA or potentiometer. Or specify special command signal.

Dimensions

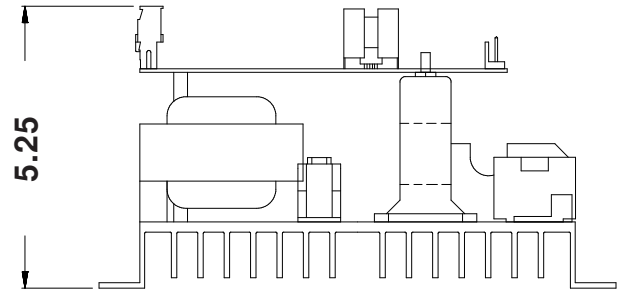
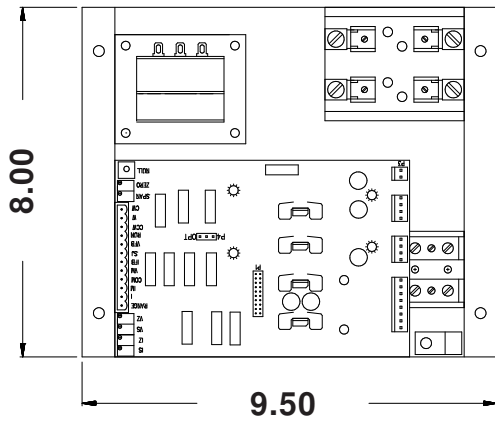

Dimensions of 50 Amp frame
Current Option Board adds 1 INCH to 5.25 Dimension

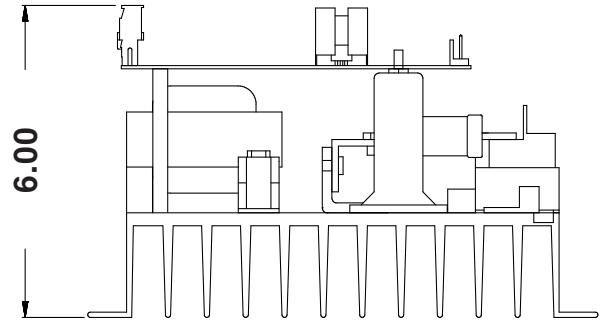
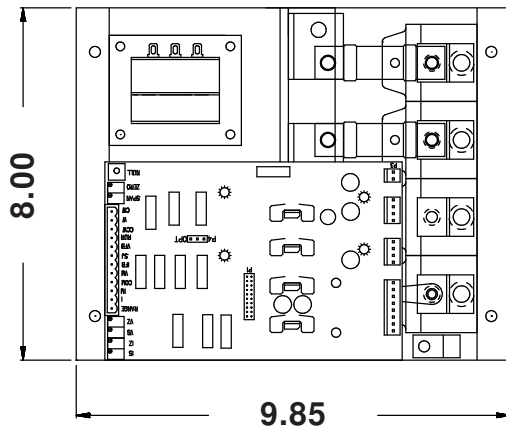

Dimensions of 75 Amp frame
Current Option Board adds 1 INCH to 6.00 Dimension

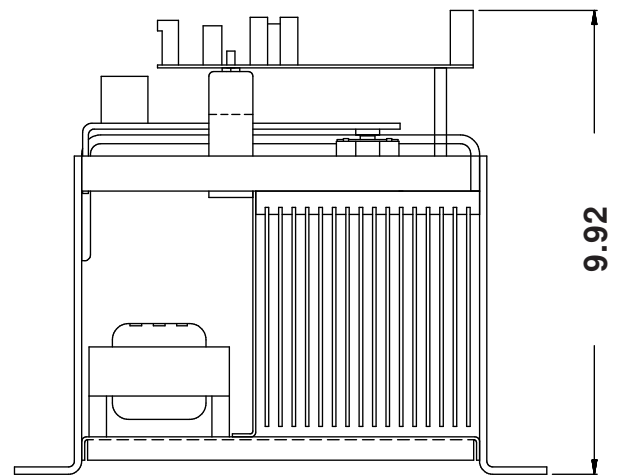
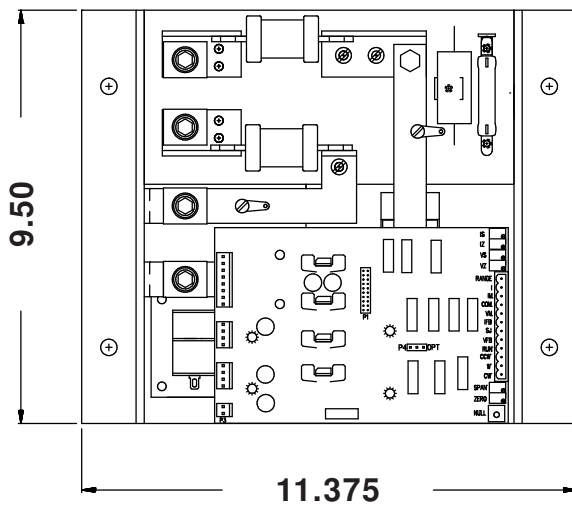

Dimensions of 180 Amp frame
Current Option Board adds 1 INCH to 9.92 Dimension

Current Option Board

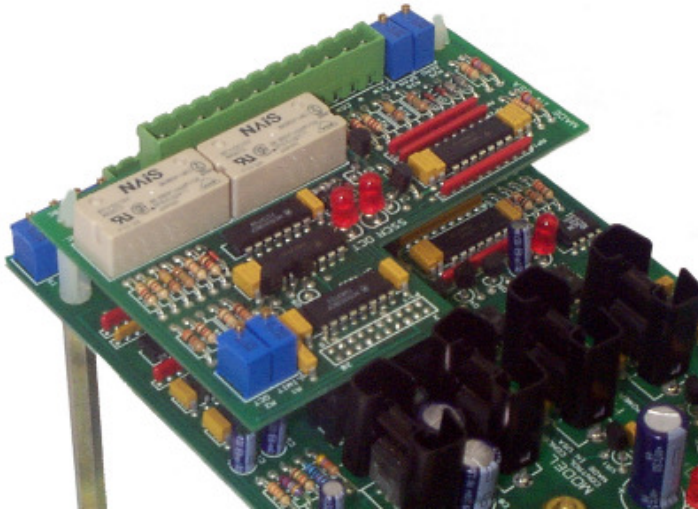

The 1039I Current Option Circuit attaches to the model 1039 controller board, and provides the additional features of current limiting, over current trip, shorted SCR detection, and a means to provide auto/manual control.

AUTO/MANUAL CONTROL:

The Current Option Circuit provides the means which allows the controller to be operated by a second, alternate input signal from a process controller such as: 0 to 5Vdc, 4 to 20mA, or by 1K potentiometer.

Closure of a switch connected between the terminals labeled "SEL" and "CCW" of P2 on the 1039I Current Option Circuit board switches the command control from the standard input on the 1039 controller board to the alternate input on the Current Option Board.

This feature provides a convenient method of providing input signals for "RUN", and "IDLE" settings. In this situation, a control signal, such as 4/20 mA, 0 to 5Vdc or 1K potentiometer, would be connected to the command input on the 1039 main circuit card, and an alternate control signal would be connected to the command input on the 1039I Current Option Circuit. One command input could be used for the desired output for "RUN" conditions, and the other could be set for the desired output for "IDLE" conditions.

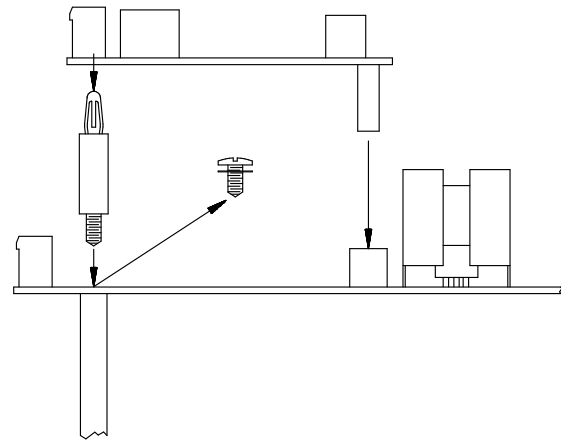

Simple Field Installaton

OVER CURRENT TRIP:

The over current trip operates within one-half of an electrical cycle to prevent further operation of the SCRs, and it causes a relay to energize with form "C" contacts which may be used to remove system power and/or activate an alarm. The controller is reset by either removing the power from the system or by momentary closure of a switch connected between the terminal labeled reset, and the terminal labeled CCW on connector P2 on the 1039I Current Option Circuit.

CURRENT LIMITING:

The model 1039 can be factory configured to linearly control, with respect to a command signal, the RMS value of either the load voltage or the current applied to the load. With the addition of the 1039I Current Option Circuit, the current limit can be adjusted to prevent the load current from exceeding a preset value. This feature is useful for preventing excessive load current from occurring when variable impedance loads are used.

SHORTED SCR DETECTION:

If an SCR fails as a short, allowing full power to be applied to the load, a relay with form "C" contacts is energized, which can be used to activate an alarm or cause system power to be removed. These contacts are accessible through connector P2 on the 1039I Current Option Circuit.

Manufactured by:



800.765.2799 | www.ccipower.com
Phone: 952.474.6200 Fax: 952.474.6070
7870 Park Drive, Chanhassen, MN 55317, U.S.A.